

aerospace
climate control
electromechanical
filtration
fluid & gas handling
hydraulics
pneumatics
process control
sealing & shielding

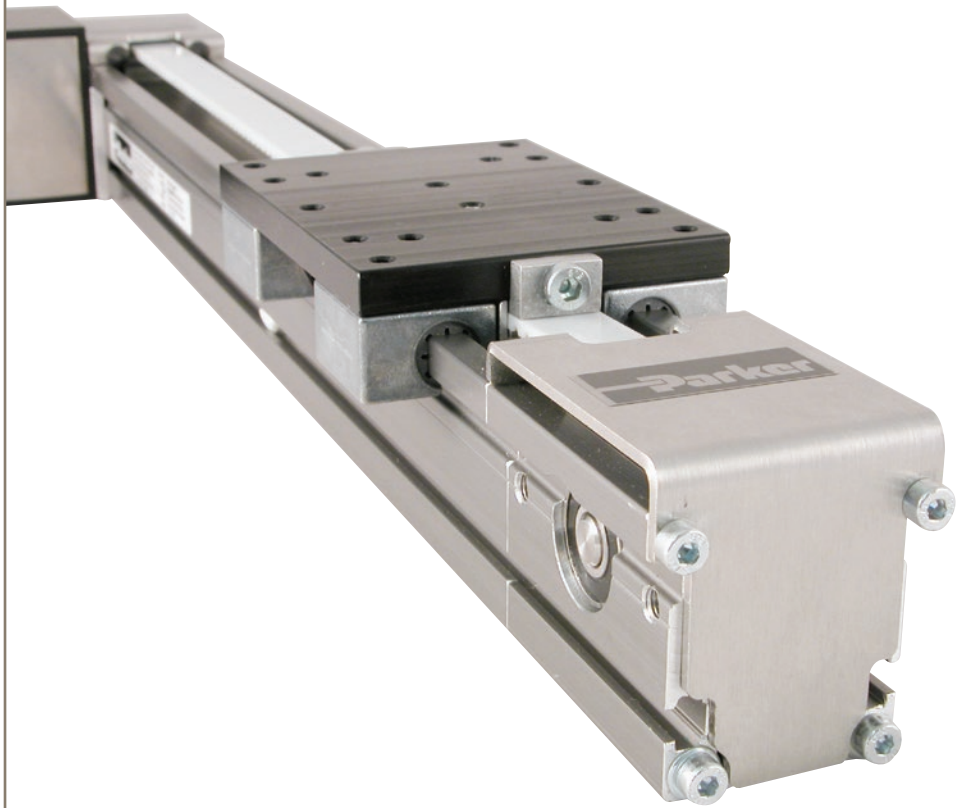

LCB - Compact Linear Actuator

Toothed belt actuator with sliding bearing

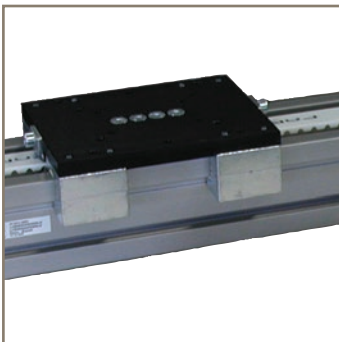
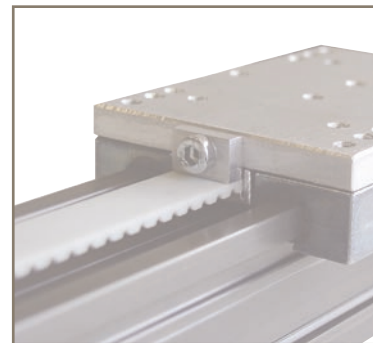

ENGINEERING YOUR SUCCESS.



WARNING – USER RESPONSIBILITY

FAILURE OR IMPROPER SELECTION OR IMPROPER USE OF THE PRODUCTS DESCRIBED HEREIN OR RELATED ITEMS CAN CAUSE DEATH, PERSONAL INJURY AND PROPERTY DAMAGE.

- This document and other information from Parker-Hannifin Corporation, its subsidiaries and authorized distributors provide product or system options for further investigation by users having technical expertise.
- The user, through its own analysis and testing, is solely responsible for making the final selection of the system and components and assuring that all performance, endurance, maintenance, safety and warning requirements of the application are met. The user must analyze all aspects of the application, follow applicable industry standards, and follow the information concerning the product in the current product catalog and in any other materials provided from Parker or its subsidiaries or authorized distributors.
- To the extent that Parker or its subsidiaries or authorized distributors provide component or system options based upon data or specifications provided by the user, the user is responsible for determining that such data and specifications are suitable and sufficient for all applications and reasonably foreseeable uses of the components or systems.

Overview	4
Technical Data	7
Load Diagrams / Wear.....	8
Location of Mass or Point of Force Application	10
Required Drive Torque	11
Deflection vs. Distance between Mountings and Payload.....	12
Dimensions	13
Accessories and Options	14
Sliding Block.....	14
External Buffers	14
Clamping Profiles.....	15
T-Nuts/Bolts	16
Electrical Limit Switches	17
Coupling Kits	18
Shaft Kit for Dual Axis Actuators.....	19
PTN Economy Planetary Gearbox for the LCB Compact Linear Actuator	20
Order Code	22
Order Code LCB Linear Actuator (Basic Unit).....	23
Order Code for the LCB Coupling Kit	24
Order Code LCB Shaft Kit (for Dual Axis Actuators).....	24
Gear Unit.....	25

Compact Linear Actuator - LCB

Overview

Description

LCB is a compact, robust linear actuator with an external sliding guidance system and integrated toothed belt drive. The construction is simple, economic and robust, which makes LCB a cost-effective alternative to traditional toothed belt actuators.

Typical areas of application

- Pick-&-Place applications
- Packaging, labeling and wrapping systems
- Sensor and format adjustment (e.g. back-stop)
- Pusher-, picker- and gripper applications
- Positioning
- Feeding
- Cutting

Features

- **Low purchase and installation costs**
- **Low operating costs:**
 - Maintenance-free (up to the wear limit of the sliding carriage)
 - Changing the replaceable slide can be carried out within a few minutes
 - High service life
 - Due to the low moving mass, energy costs are reduced
- **Motion is controlled using modern servo or stepper motor technology. This allows any required position or velocity profile to be achieved**
- **Even at high speeds the LCB generates very little noise**
- **The slide guidance system is clean and dry. There is no need for lubrication that can attract dust particles.**
- **The sliding guide system has a high static load bearing capacity**
- **Simple mounting**
 - Integrated grooves allow for easy assembly of the LCB. Additional components such as limit switches can also be fitted with no restrictions on the position along the groove.
- **The LCB is available with different drive packages**
 - as components with free shaft end
 - fitted with a gearbox
 - with a gearbox and servo or stepper motor drive
 - with a gearbox and servo motor combined with a matching closed loop controller from Parker (Compax3 or PSD)
 - with a (direct-drive option) servo motor and Compax3 servo controller

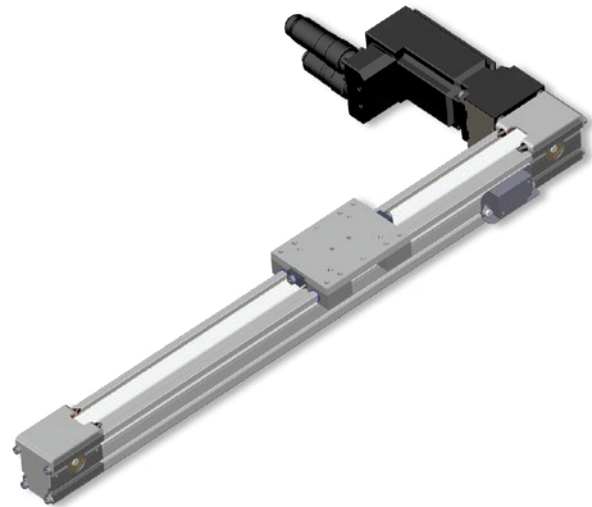

Technical Characteristics - Overview

Module type	Linear Actuator with Toothed Belt Drive
Frame size	LCB040
Speed	up to 8 m/s
Acceleration	up to 20 m/s ²
Load capacity	1250 N
Total Stroke	2000 mm
Thrust force	160 N
Typical payload	1...6 kg
Repeatability	±0.2 mm

Cross section M1:1

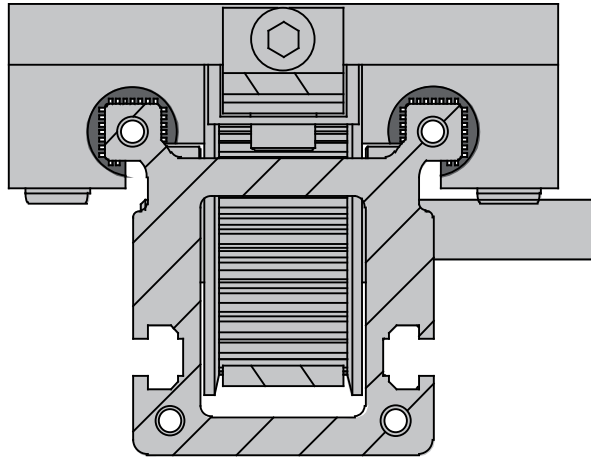

LCB040

Product Design

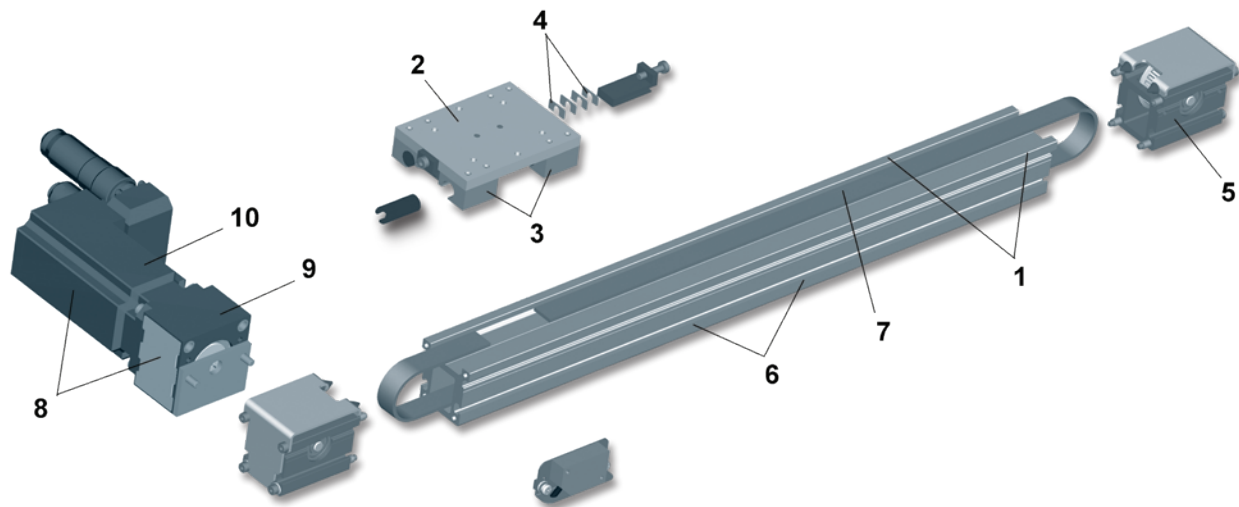

The LCB is protected by registered design No. 20 2004 014 821.8

Guide (1) / sliding carriage (2):

- The external sliding guide is incorporated as part of the aluminum profile. The guiding rails do not have to be aligned.
- The sliding carriage is available in three lengths. With a longer sliding carriage there is greater distance between the sliding blocks (3) and this improves the load capacity with respect to yawing and pitching moments.
- Maintenance-free sliding guiding with integrated dry-film lubricant.
- Sliding carriage (3) can be easily changed within 2 minutes without detensioning the toothed belt.
- The toothed belt of LCB40 is tensioned directly at the sliding carriage by means of spacer plates (4).
- The low moving mass allows highly-dynamic movement to be achieved and saves operating power.

Profile (6):

- High resistance to flexing

- High torsional stiffness (due to the closed profile)
- Compact design, optimum space utilization
- Dirt tolerant, chemically and mechanically robust

Toothed belt drive (7):

- High stiffness and accuracy provided by the generously-dimensioned toothed belt.

Drive (8):

- Drive options:
 - Linear actuator with free shaft end

- Coupling (9) & gearbox
- Coupling + gearbox/motor combination (stepper or servo)
- Coupling, gearbox, motor and controller
- Coupling and motor (10) (direct-drive with Compax3 / PSD)

Right/left Indication

Looking from load attachment plate to drive module.

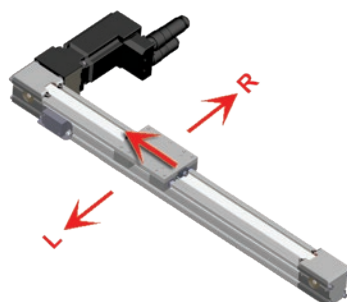

Technical Data

The technical data apply under normal conditions and only for the individual operating and load mode. In the case of compound loads, it is necessary to verify in accordance with normal physical laws and technical standards whether individual ratings should be reduced. In case of doubt please contact Parker Hannifin.

LCB - Size	Unit	LCB040
Travels, speeds and accelerations		
Maximum travel speed	[m/s]	5
Maximum acceleration	[m/s ²]	20
Maximum stroke	[mm]	2000
Torques, forces, dimensions of pulley and timing belt		
Travel distance per revolution	[mm/U]	125
Diameter of pulley	[mm]	39.79
Toothed belt width / pitch	[mm]	16 / 5
Weight of toothed belt	[kg/m]	0.048
maximum drive torque	[Nm]	3.2
Static load capacity in normal direction	[N]	1250
max. thrust force (effective load)	[N]	160
Repeatability	[mm]	±0.2
Weights, mass moments of inertia		
Weight of base unit without stroke		
LCB with short sliding carriage	[kg]	1.47
LCB with medium sliding carriage	[kg]	1.66
LCB with long sliding carriage	[kg]	1.85
Weight of moved mass with short sliding carriage	[kg]	0.39
Weight of moved mass with medium sliding carriage	[kg]	0.46
Weight of moved mass with long sliding carriage	[kg]	0.53
Additional weight per meter of stroke	[kg/m]	2.45
Mass moment of inertia relative to the drive shaft		
LCB with free shaft, short sliding carriage, 1 m of stroke	[kgmm ²]	244
LCB with free shaft, medium sliding carriage, 1 m of stroke	[kgmm ²]	272
LCB with free shaft, long sliding carriage, 1 m of stroke	[kgmm ²]	300
Mass moment of inertia of coupling	[kgmm ²]	1
Additional mass moment of inertia due to the weight of the toothed belt per meter of stroke	[kgmm ² /m]	37
Overall dimensions & physical data		
Length with short sliding carriage, zero stroke	[mm]	246
Length with medium sliding carriage, zero stroke	[mm]	296
Length with long sliding carriage, zero stroke	[mm]	346
Cross-section	[mm x mm]	40 x 60 x 73
Moment of inertia I _x	[cm ⁴]	17.93
Moment of inertia I _y	[cm ⁴]	17.79
Moment of inertia I _t	[cm ⁴]	35.68
E-modulus (aluminum)	[N/mm ²]	0.72 x 10 ⁵
Temperature data		
Temperature range	-20 °C to +60 °C The nominal data are valid for ambient temperatures between +15 °C and +30 °C.	

Technical data considering safety factor S=1.

Load Diagrams / Wear

Prerequisites:

The diagrams apply for ideal operating conditions, faultless guidings provided. Please note that they are only valid for the guiding. The diagrams are based on a trapezoidal motion profile consisting of 3 equally long distances for acceleration, constant travel and deceleration.

The diagrams are normalized on defined payloads: LCB040 with 1 kg.

Shown are the respective mass centroids with their typical load arms.

Lifetime:

Naturally, the sliding guide already has a small amount of play from new so that the guide does not jam and the sliding carriage moves smoothly. The play is measured as a gap for each slide and is approx. 0.1 to 0.2 mm in normal direction and at the sides.

During operation, play increases according to the loads

shown in the diagrams.

If the slide has worn, or reached the wear limit (0.5 mm for LCB040), the slides can easily be changed within a few minutes. Once replaced, the life of the product is effectively renewed and once again follows the Load/wear diagrams.

Use of the diagrams:

The diagrams can be interpolated with respect to lifetime and extrapolated with respect to load (for example: halved operational performance results in halved wear, doubled load will result in halved mileage in km).

LCB040 - Lifetime / Sliding blocks for different mass centroids with their typical load arms.

Normalized payload 1 kg

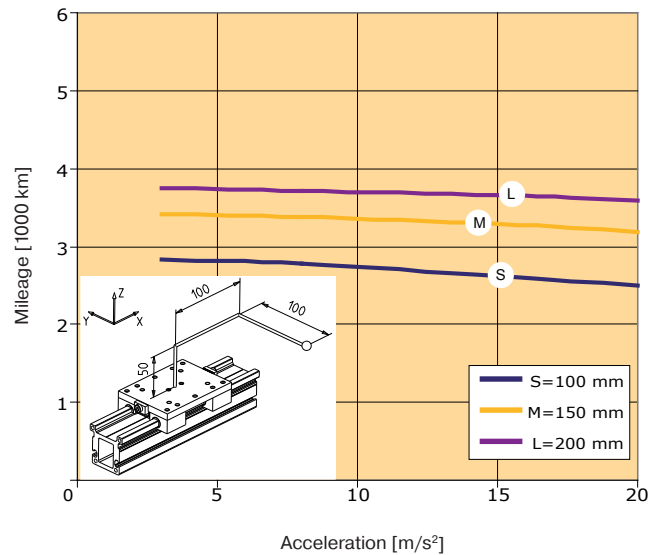
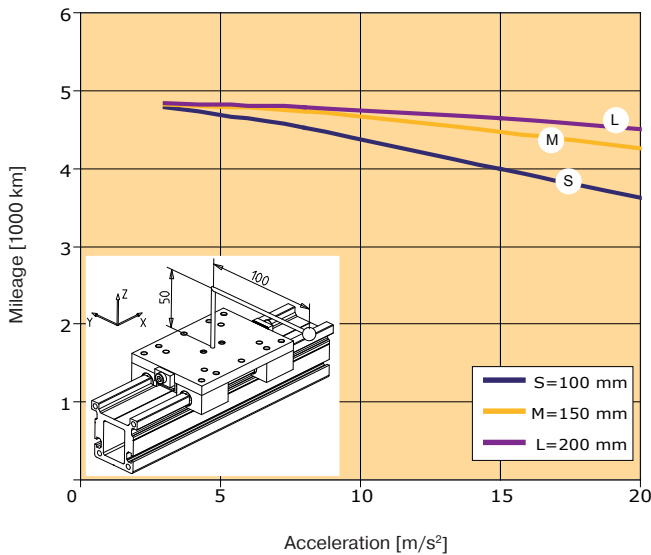
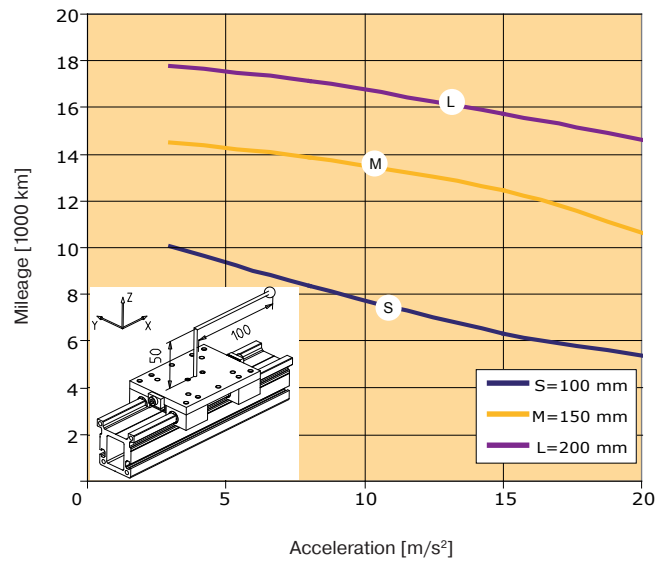
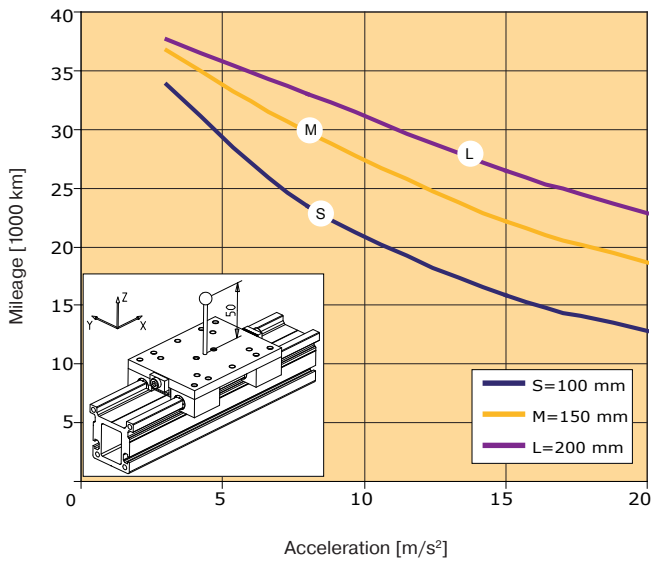

LCB040 - Lifetime / Sliding blocks for different mass centroids with their typical load arms.
Normalized payload 1 kg

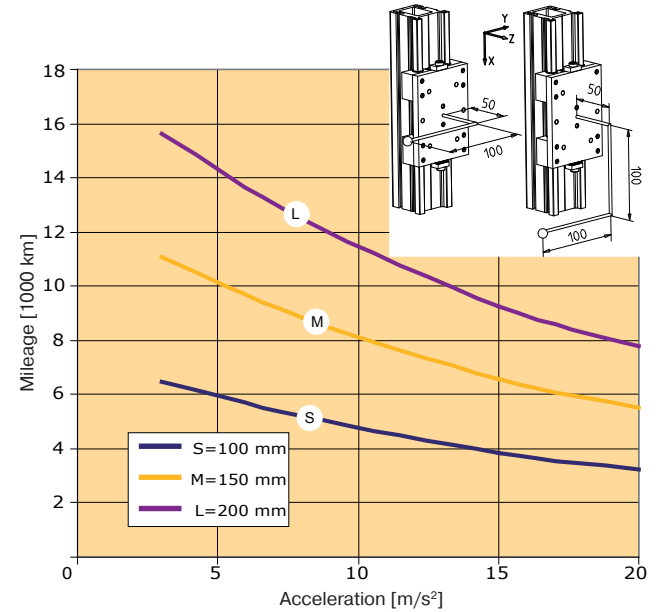
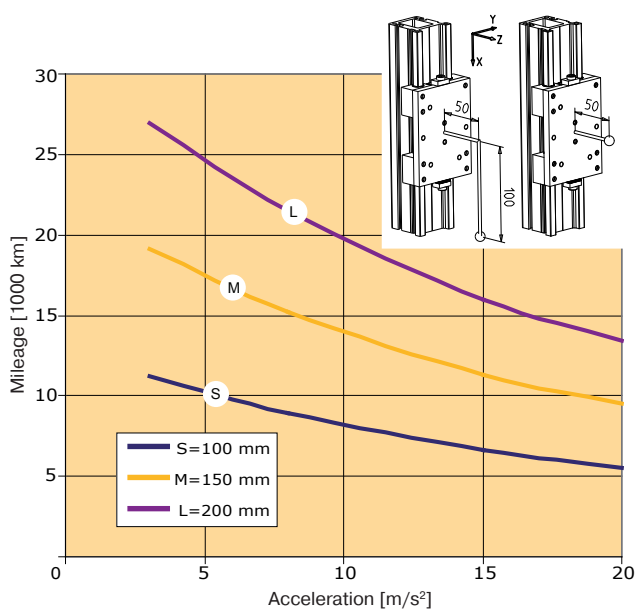
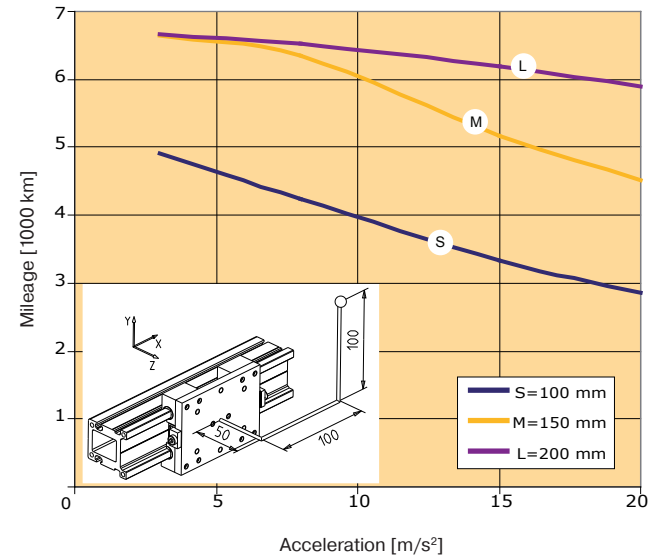
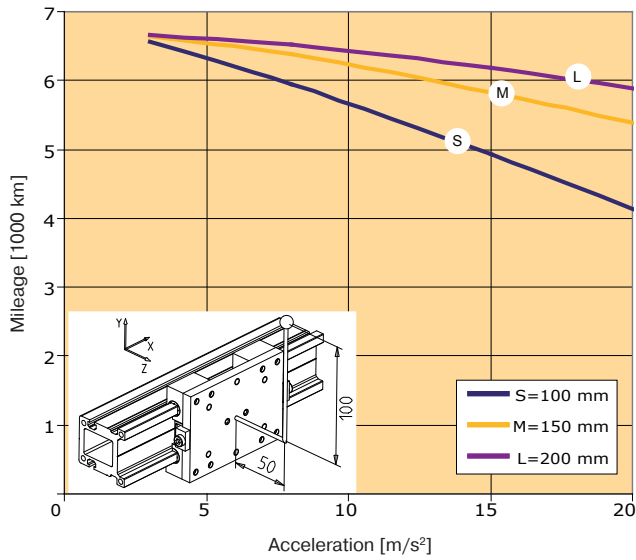
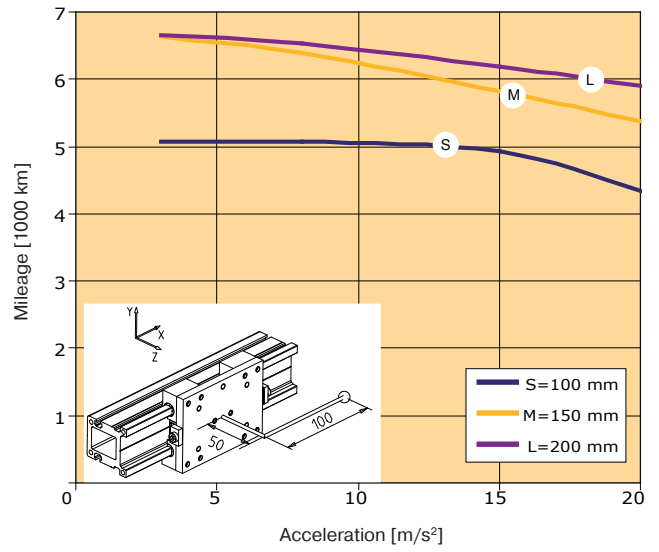
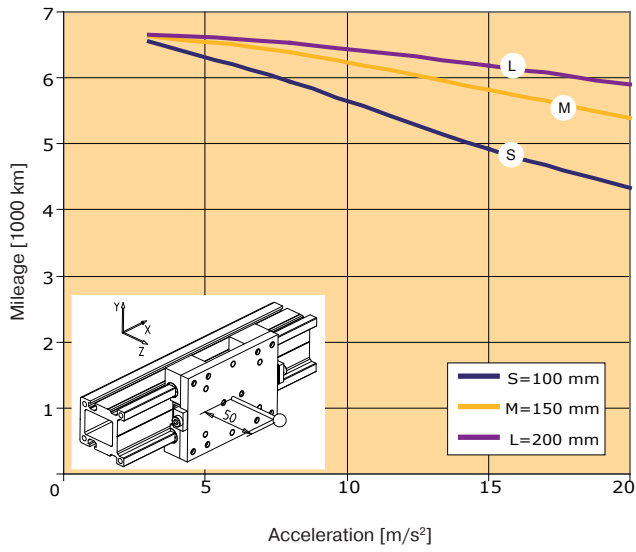

Location of Mass or Point of Force Application

2:1 rule

The displayed example of a pitching moment is also valid for rolling and yawing moments respectively.

l_L = Load lever

l_T = Support lever

* = Exact point of force application

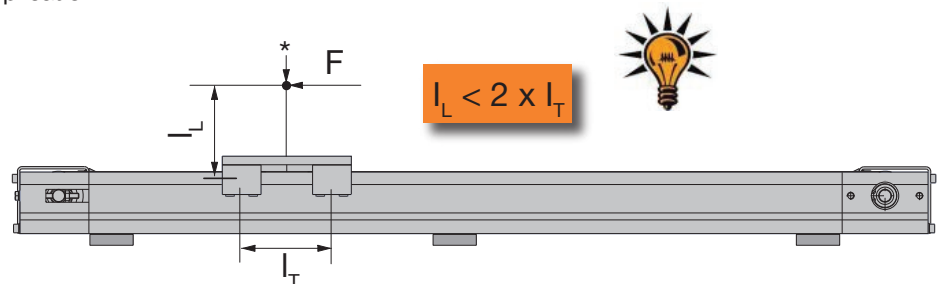

Required Drive Torque



The diagrams include both acceleration and friction forces!
 The values displayed are valid for averaged kinetic friction.

LCB040 - required drive torque

horizontal mounting position

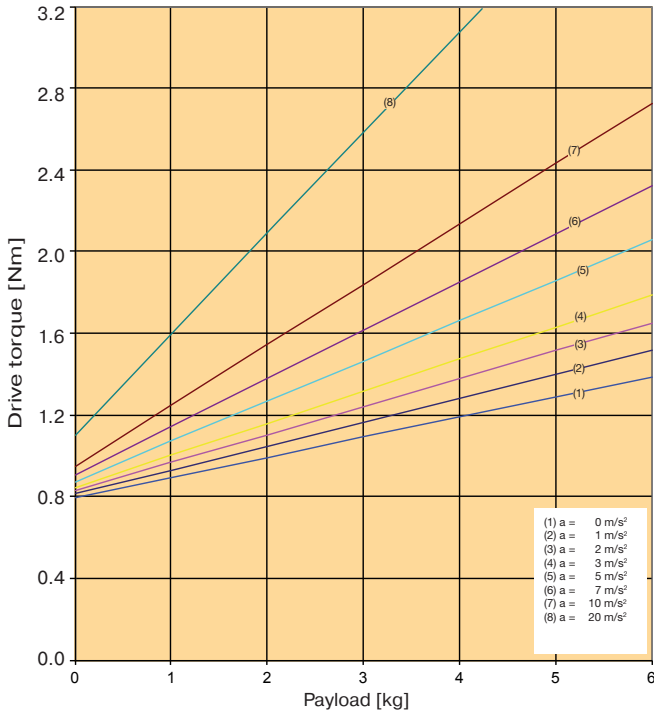

vertical mounting position (upward acceleration)

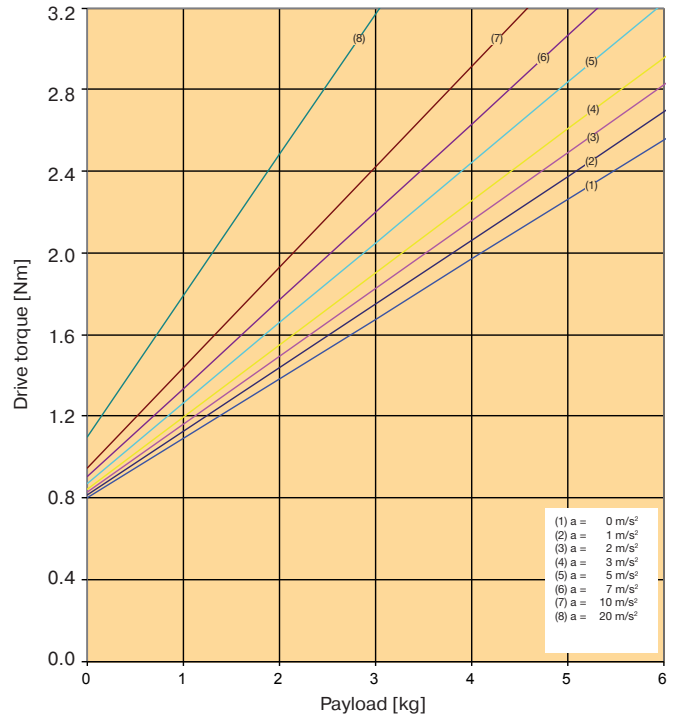

- (1): Constant movement
 (2) - (8): Acceleration

Deflection vs. Distance between Mountings and Payload

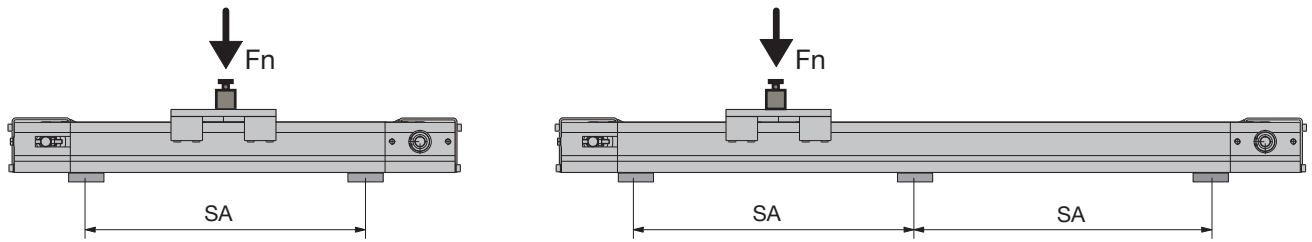

LCB040

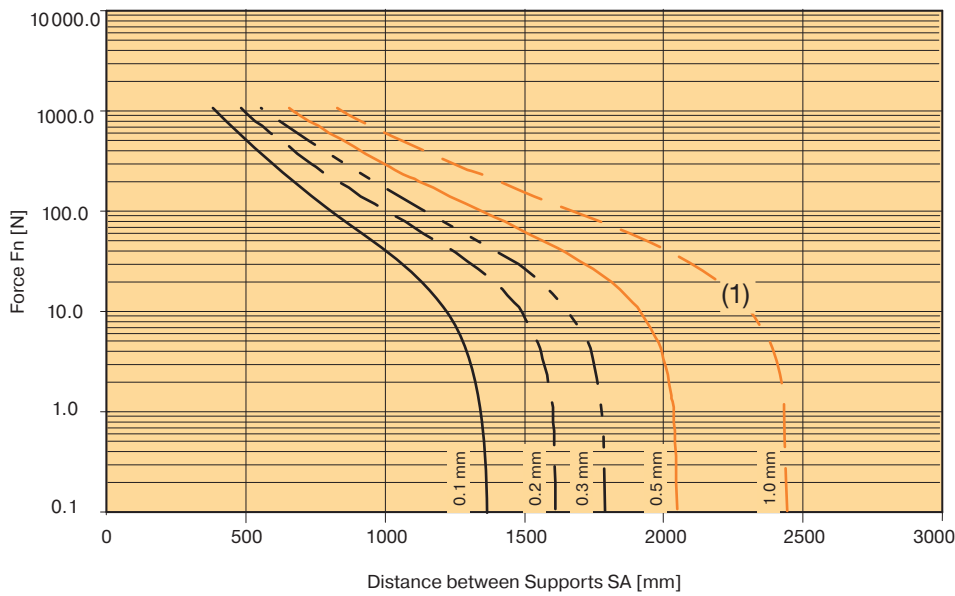

Dimensions

LCB040 Linear actuator

3D-CAD Data: www.parker.com/eme/lcb

Dimensions [mm]



Right/left Indication

Section A-A

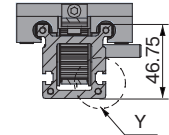

Required space for exchanging the sliding foil

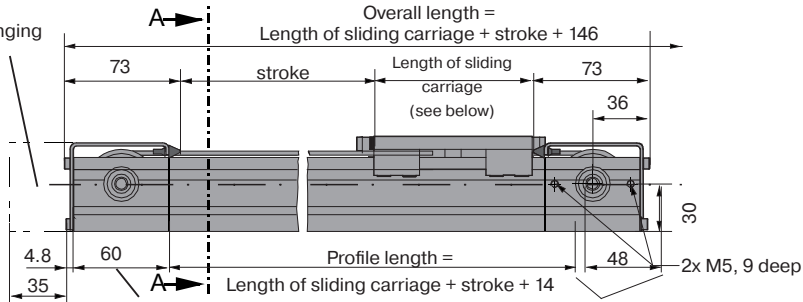
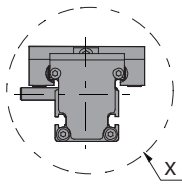

Please do not fix the actuator in this area

Please do not fix the actuator in this area

Detail Y (enlarged)

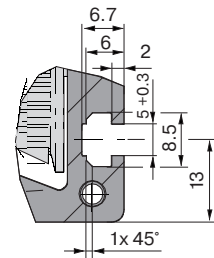

Detail X (enlarged)

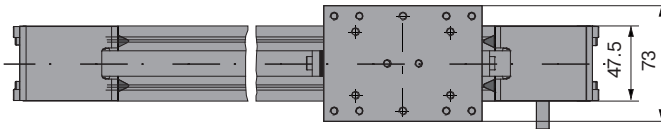
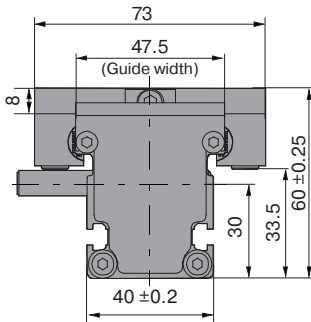

Length of sliding carriage

All sliding carriages have 4 sliding blocks.

On a longer sliding carriage the load bearing capacity for yawing and pitching moments is greater (M_y and M_z).

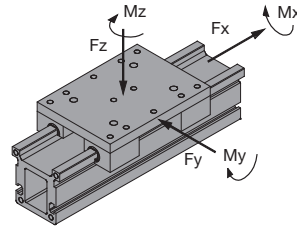

Carriage options

Short sliding carriage S

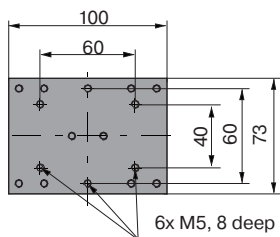

Medium sliding carriage M

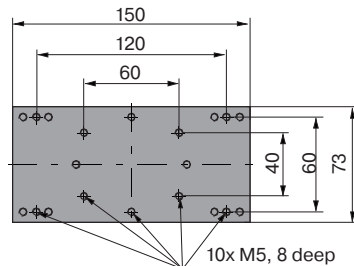

Long sliding carriage L

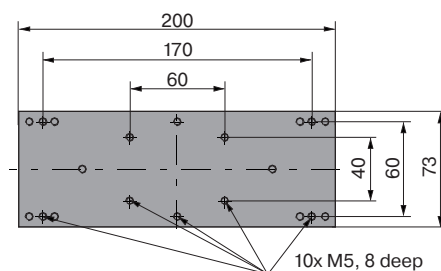

Drive options

Drive station SL

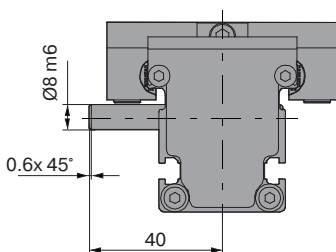

Drive station SR

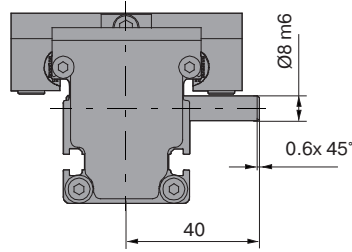

Drive station BL/BR

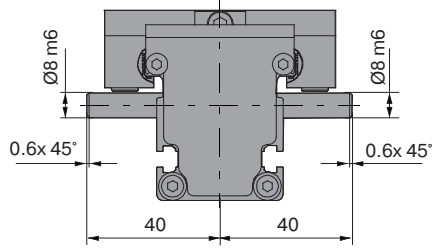

Accessories and Options

Sliding Block

The sliding block is a wearing part.
You need 4 pieces per linear actuator .

Type	Code	Art. No.
LCB040	Sliding bearing block	127-004016

We recommend to have at least 4 sliding blocks on stock.

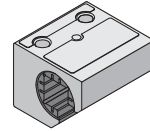

External Buffers

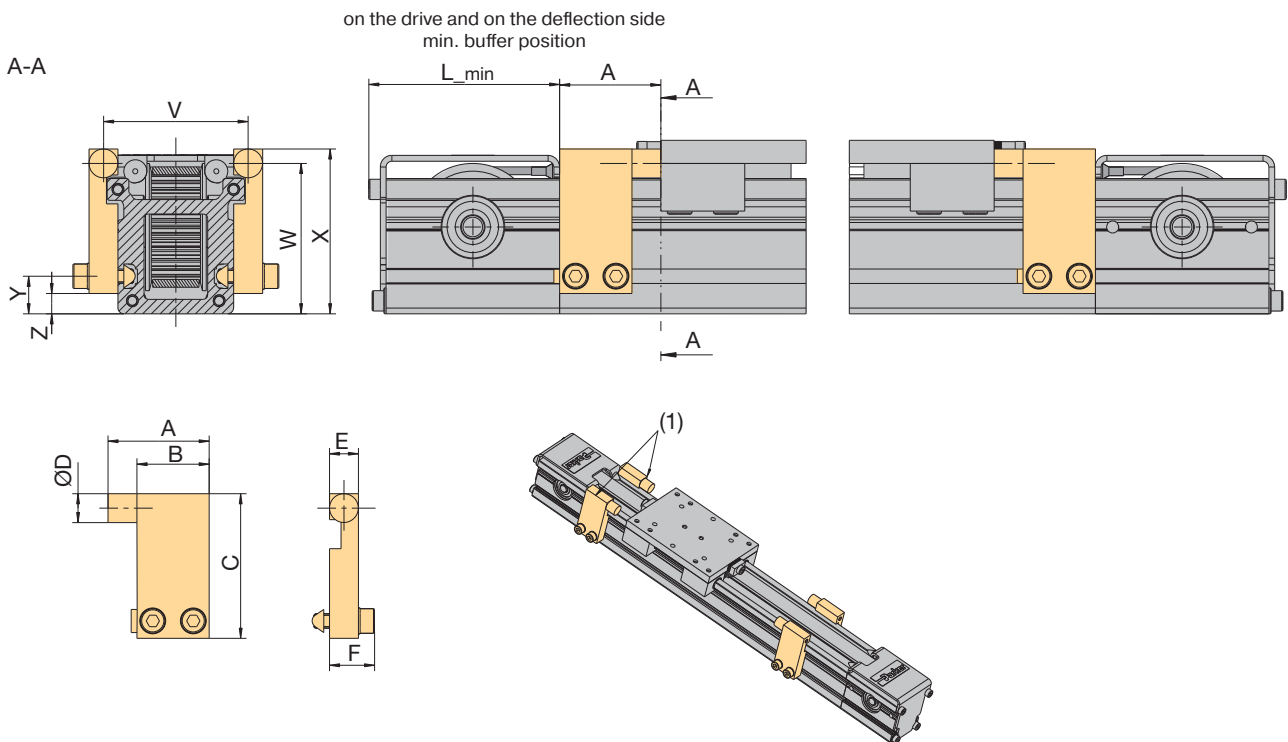

(1) We recommend 2 external buffers are fitted per side.

Type	Code	Art. No.	Art. No.	A	B	C	ØD	E	F
			stainless	[mm]					
LCB040	buffer assembly	510-001445	510-001495	35	25	50	10	10	15.6

Type	L_min	V	W	X	Y	Z
	[mm]					
LCB040	66	50	52	57	13	7

Clamping Profiles

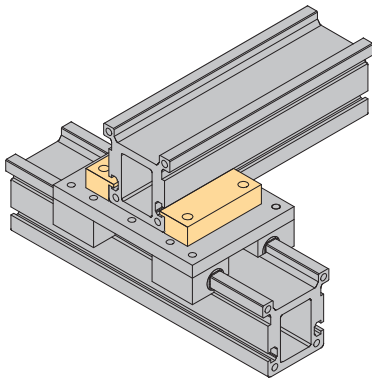

The toe clamps are used in conjunction with the standard load attachment plate to rapidly install and attach various combinations of linear actuators. Two clamping profiles are needed to fix a LCB on a flange plate. (The clamping profiles may not be used in the area of the drive- or of the clamping station).

LCB040

Dimensions [mm]

Type	Code	Art. No.
LCB040	Toe Clamp	500-000910

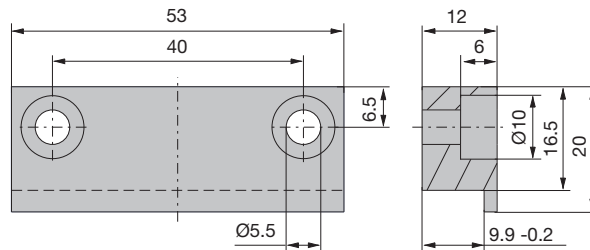
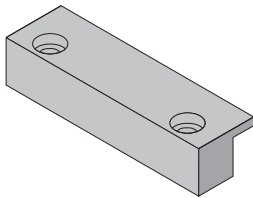

T-Nuts/Bolts

The T-nuts and bolts are used to attach external components to the T-grooves of the profile

Nuts

Dimensions [mm]

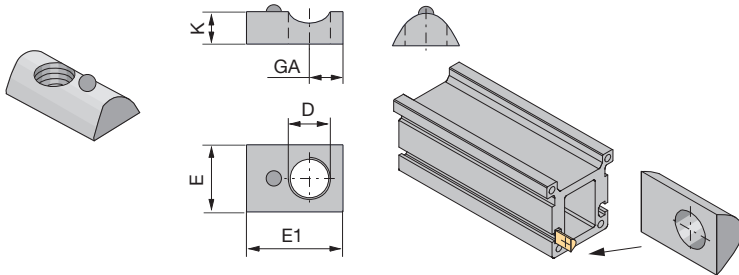

T slot bolts and nuts

DIN 562

DIN 934

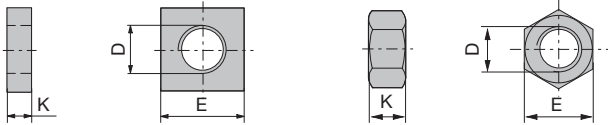

Type	Code	D	E	E1	K	GA	L	Art. No.
LCB040	Nut	M4	8	11.5	4	4	--	127-004020
LCB040	Nut	M5	8	11.5	4	4	--	127-004021
LCB040	DIN 562-M4 square nut*	M4	7	--	2.2	--	--	135-700001
LCB040	DIN 562-M5 square nut*	M5	8	--	2.7	--	--	135-700003
LCB040	DIN 934-M4 hexagon nut*	M4	7	--	2.9	--	--	135-700600
LCB040	DIN 934-M5 hexagon nut*	M5	8	--	3.7	--	--	135-700700

* Square and hexagon nuts should only be used for lightly-loaded attachments

Electrical Limit Switches

Dimensions [mm]

LCB040

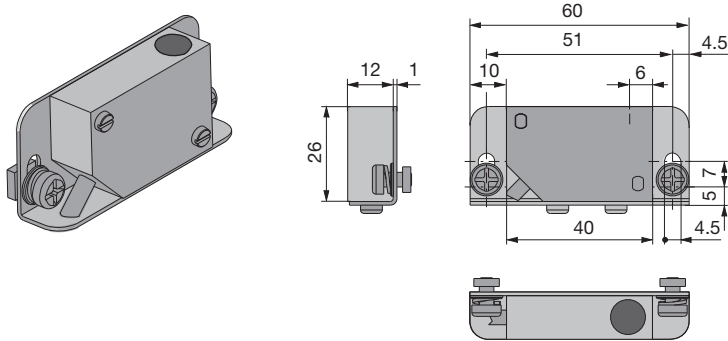

Connection diagram LCB040

Technical data limit switches LCB040	
Switching distance	2 mm / 4 mm ±10 %
Switch hysteresis	>1 %...<15 %
Repeatability	0.01 mm
Temperature drift	<10 %
Ambient temperature	-25 °C...+70 °C
Protection class	IP67
Cable length	6 m
Electrical characteristics	
Rated voltage	24 VDC
Voltage range	10...35 VDC
Supply current	<15 mA
Maximum load current	300 mA
Residual voltage	<2.5 VDC
Switching Frequency	2 kHz
Connecting cables	3x0.25 mm ²

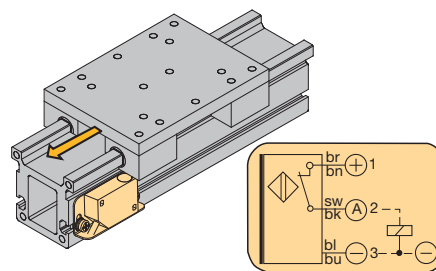

1: PNP normally closed contact
2-3: Load

Type	Code	Art. No.
LCB040	Electrical limit switch NPN normally closed contact with 6 m cable and fixing material	510-001435
LCB040	Electrical limit switch NPN normally open contact with 6 m cable and fixing material	510-001436
LCB040	Electrical limit switch PNP normally closed contact with 6 m cable and fixing material	510-001437
LCB040	Electrical limit switch PNP normally open contact with 6 m cable and fixing material	510-001438

Coupling Kits

LCB with attached coupling kits

If a coupling kit is ordered in combination with a basic unit, the items will be delivered completely mounted. BL and BR have an additional shaft on the opposite side of the coupling. This is used to attach the shaft kit for dual-axis actuators.



Dimensions [mm]

Drive options

Drive option L

LCB040 prepared for planetary gearbox PTN060

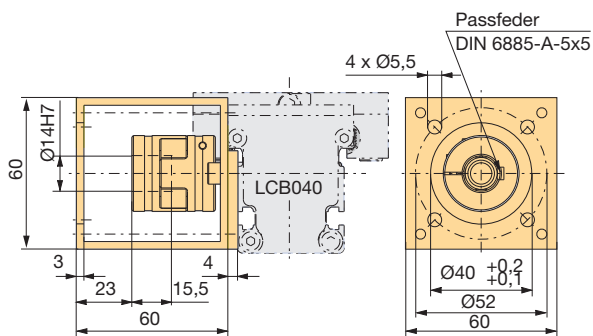

Drive option U

LCB040 prepared for servo motor SMH60 (direct drive)
only for single actuators with horizontal installation
position

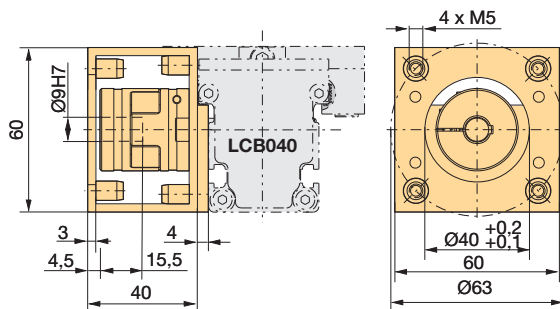

Shaft Kit for Dual Axis Actuators

For a dual-axis actuator two LCB basic units and a shaft kit corresponding to the desired center-distance are required. Parker will deliver the two basic units (with mounted couplings - if this was ordered) and a separate shaft-kit.

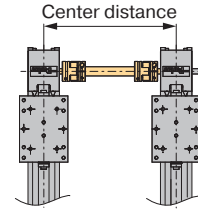

LCB040

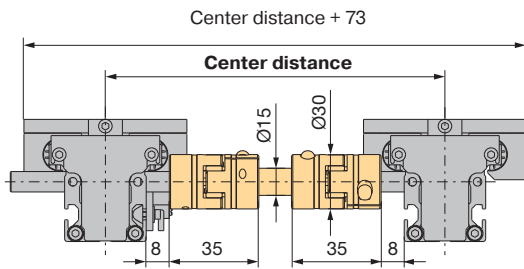

Possible double-axis configurations

For a dual-axis actuator with the drive on the left side you need two LCB basic units. The left unit with drive option BLN, the right unit with drive option SLN.

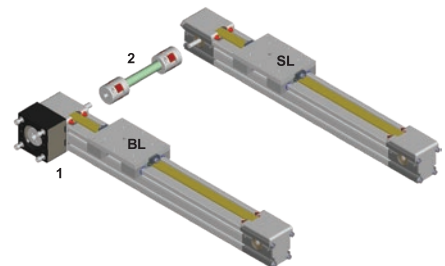

1: Coupling kit
2: Shaft kit

For a dual-axis actuator with the drive on the right side you need two LCB basic units. The right unit with drive option BRN, the left unit with drive option SRN.

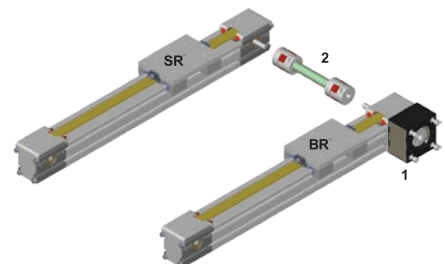

1: Coupling kit
2: Shaft kit

PTN Economy Planetary Gearbox for the LCB Compact Linear Actuator

PTN planetary gearbox in two sizes

Description

The economy series PTN planetary gearbox was developed for applications, where an extremely low backlash is not required.

- Space-saving design
- High output torques
- High efficiency (96 %)
- Low noise <65 dB (A)
- Life time lubrication
- High quality (ISO 9001)
- Fast and direct motor mounting
- Direction of rotation equidirectional
- Ratios: 4:1, 8:1, 25:1



Dimensions

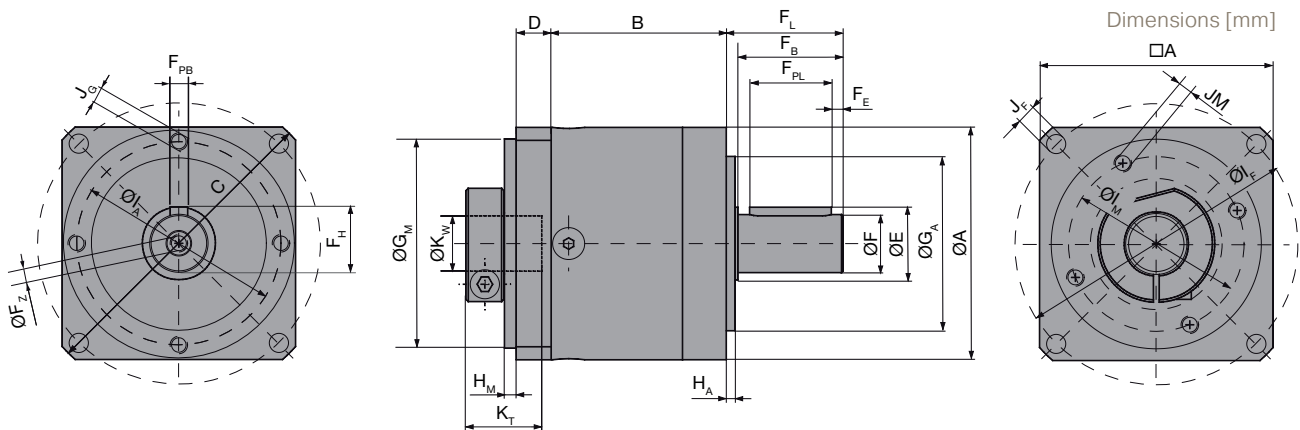

Gearbox size		PTN060
A	Ø Housing □ Universal flange cross section	60
B	Housing length (ratio 4:1, 8:1)	47
	Housing length (ratio 25:1)	59.5
C	Diagonal dimension of universal flange	80
D	Thickness of universal flange	8.2
E	Ø Shaft collar	17
F	Ø Drive shaft (h7)	14
F _Z	Centre bore of drive shaft	M5x12
F _L	Shaft length from face	35
F _B	Usable shaft length	30
F _H	Shaft height with key	16
F _E	Distance from keyway to shaft end	2.5

F _{PL}	Length of keyway	25
Gearbox size		PTN060
F _{PB}	Width of keyway	5
G _A	Ø Output pilot (h7)	40
G _M	Ø Input pilot (h7)	52
H _A	Output pilot length	3
H _M	Output drive length	3
I _A	Ø Hole circle on pilot side	52
I _M	Ø Hole circle on output side	44
I _F	Ø hole circle of universal flange	70
J _G	Mounting thread on pilot side	M5x8
J _M	Mounting thread on output side	M5x8
J _F	Ø mounting thread universal flange	5.5
K _W	Ø Input bore	9
K _T	Input shaft bore depth	20

Technical Data

Gearbox size	Unit	PTN060		
		4:1	8:1	25:1
Ratio		4:1	8:1	25:1
Nominal torque	Nm	38	18	40
Backlash	arcmin	<16		<20
Torsional rigidity	Nm/arcmin	2.3		2.5
Noise emission	dB(A)	<58	<58	<60
Efficiency	%	>96	>94	>96
Weight	kg	0.9	1.1	2.1
Input speed ⁽¹⁾	min ⁻¹	4500		
Load on output shaft ⁽²⁾ radial	N	500		
Load on input shaft ⁽²⁾ axial	N	600		
Operating temperature	°C	-25...+90		
Moment of Inertia	kgcm ²	0.093	0.065	0.075

⁽¹⁾ Intermittent operation, the max. permissible operating temperature is not to be exceeded.

⁽²⁾ Based on a lifetime of 20 000 hours - working cycle of 50 %

Order Code

The order code is structured as follows:

Basic unit:

"Order Code LCB Linear Actuator (Basic Unit)" see page 23

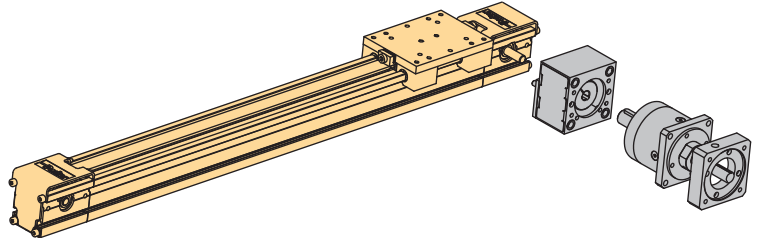

Coupling kit:

"Order Code for the LCB Coupling Kit" see page 24

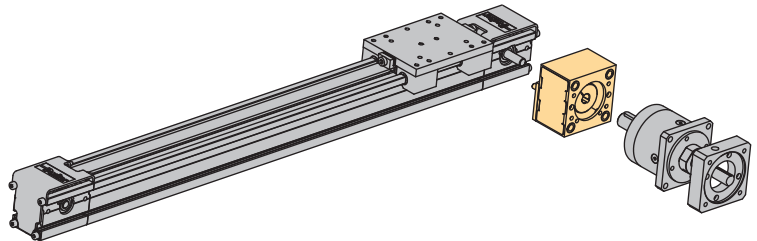

Shaft kit for dual axis actuators:

"Order Code LCB Shaft Kit (for Dual Axis Actuators)" see page 24

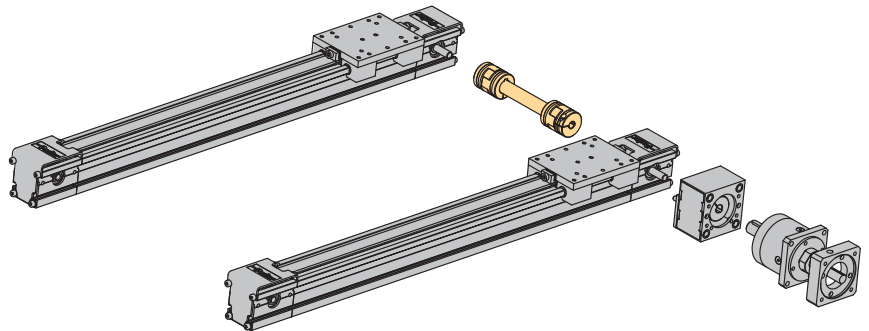

Gear unit:

Gearbox: "Order Code PTN Economy Planetary Gearbox" see page 25

Motor kit: "Order Code for Motor Kit (Adapter Flange and Adapter Sleeve if applicable)" see page 25

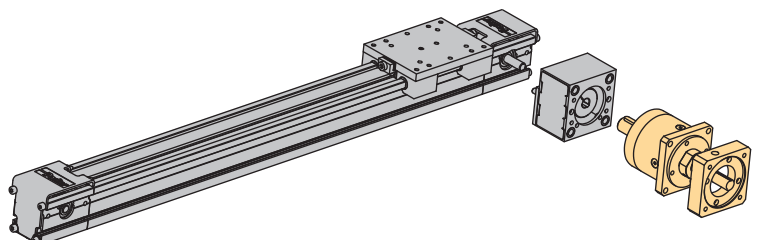

Order Code LCB Linear Actuator (Basic Unit)

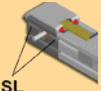
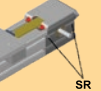
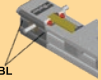
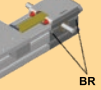
	Example	LCB	040	M	G	00250	SR	N	
Drive system									
LCB linear actuator		LCB							
Frame size									
040 (LCB040)			040						
Length of sliding carriage in mm									
		LCB040							
Short sliding carriage		100		S					
Medium sliding carriage		150		M					
Long sliding carriage		200		L					
Special carriage (on request)				X					
Guide system									
Sliding guide					G				
Stroke in mm									
Depending on your application an additional safety travel on both sides of your travel path could be necessary.		LCB040							
250		√				00250			
300		√				00300			
350		√				00350			
400		√				00400			
450		√				00450			
500		√				00500			
600		√				00600			
700		√				00700			
800		√				00800			
900		√				00900			
1000		√				01000			
1250		√				01250			
1500		√				01500			
1750		√				01750			
2000		√				02000			
Drive station and drive orientation									
	One drive shaft, drive on left							SL	
	One drive shaft, drive on right							SR	
	Two drive shafts (shaft on both sides), drive on left, only LCB040: Feather key groove DIN6885 - 2x2x10 on the left or on the right of the drive side							BL	
	Two drive shafts (shaft on both sides), drive on right, only LCB040: Feather key groove DIN6885 - 2x2x10 on the left or on the right of the drive side							BR	
Interface to the drive									
Mandatory statement								N	

Order Code for the LCB Coupling Kit

	Example	LCB	040	K	L
Drive system					
LCB linear actuator		LCB			
Frame size					
040 (LCB040)			040		
Coupling kit*					
Coupling kit				K	
Drive Option (page 18)		LCB040			
Prepared for Planetary Gearbox PTN060		√			L
Prepared for servo motor (Direct drive) SMH60..B8, D=9 (for single actuator)		√			U

* Coupling kits are always mounted in the factory.

Order Code LCB Shaft Kit (for Dual Axis Actuators)

	Example	LCB	040	W	0250
Drive system					
LCB linear actuator		LCB			
Frame size					
040 (LCB040)			040		
Connecting shaft kit					
Connecting shaft kit				W	
Center distance (from center line to center line in mm)		LCB040			
150 mm		√			0150
200 mm		√			0200
250 mm		√			0250
300 mm		√			0300
350 mm		√			0350
400 mm		√			0400
450 mm		√			0450
500 mm		√			0500
550 mm		√			0550
600 mm		√			0600
650 mm		√			0650
700 mm		√			0700
750 mm		√			0750
800 mm		√			0800
850 mm		√			0850
900 mm		√			0900
950 mm		√			0950
1000 mm		√			1000



Parker's Motion & Control Technologies

At Parker, we're guided by a relentless drive to help our customers become more productive and achieve higher levels of profitability by engineering the best systems for their requirements. It means looking at customer applications from many angles to find new ways to create value. Whatever the motion and control technology need, Parker has the experience, breadth of product and global reach to consistently deliver. No company knows more about motion and control technology than Parker. For further info call 00800 27 27 5374



Aerospace

Key Markets

Aftermarket services
Commercial transports
Engines
General & business aviation
Helicopters
Launch vehicles
Military aircraft
Missiles
Power generation
Regional transports
Unmanned aerial vehicles

Key Products

Control systems & actuation products
Engine systems & components
Fluid conveyance systems & components
Fluid metering, delivery & atomization devices
Fuel systems & components
Fuel tank inerting systems
Hydraulic systems & components
Thermal management
Wheels & brakes



Climate Control

Key Markets

Agriculture
Air conditioning
Construction Machinery
Food & beverage
Industrial machinery
Life sciences
Oil & gas
Precision cooling
Process
Refrigeration
Transportation

Key Products

Accumulators
Advanced actuators
CO₂ controls
Electronic controllers
Filter driers
Hand shut-off valves
Heat exchangers
Hose & fittings
Pressure regulating valves
Refrigerant distributors
Safety relief valves
Smart pumps
Solenoid valves
Thermostatic expansion valves



Electromechanical

Key Markets

Aerospace
Factory automation
Life science & medical
Machine tools
Packaging machinery
Paper machinery
Plastics machinery & converting
Primary metals
Semiconductor & electronics
Textile
Wire & cable

Key Products

AC/DC drives & systems
Electric actuators, gantry robots & slides
Electrohydraulic actuation systems
Electromechanical actuation systems
Human machine interface
Linear motors
Stepper motors, servo motors, drives & controls
Structural extrusions



Filtration

Key Markets

Aerospace
Food & beverage
Industrial plant & equipment
Life sciences
Marine
Mobile equipment
Oil & gas
Power generation & renewable energy
Process
Transportation
Water Purification

Key Products

Analytical gas generators
Compressed air filters & dryers
Engine air, coolant, fuel & oil filtration systems
Fluid condition monitoring systems
Hydraulic & lubrication filters
Hydrogen, nitrogen & zero air generators
Instrumentation filters
Membrane & fiber filters
Microfiltration
Sterile air filtration
Water desalination & purification filters & systems



Fluid & Gas Handling

Key Markets

Aerial lift
Agriculture
Bulk chemical handling
Construction machinery
Food & beverage
Fuel & gas delivery
Industrial machinery
Life sciences
Marine
Mining
Mobile
Oil & gas
Renewable energy
Transportation

Key Products

Check valves
Connectors for low pressure fluid conveyance
Deep sea umbilicals
Diagnostic equipment
Hose couplings
Industrial hose
Mooring systems & power cables
PTFE hose & tubing
Quick couplings
Rubber & thermoplastic hose
Tube fittings & adapters
Tubing & plastic fittings



Hydraulics

Key Markets

Aerial lift
Agriculture
Alternative energy
Construction machinery
Forestry
Industrial machinery
Machine tools
Marine
Material handling
Mining
Oil & gas
Power generation
Refuse vehicles
Renewable energy
Truck hydraulics
Turf equipment

Key Products

Accumulators
Cartridge valves
Electrohydraulic actuators
Human machine interfaces
Hybrid drives
Hydraulic cylinders
Hydraulic motors & pumps
Hydraulic systems
Hydraulic valves & controls
Hydrostatic steering
Integrated hydraulic circuits
Power take-offs
Power units
Rotary actuators
Sensors



Pneumatics

Key Markets

Aerospace
Conveyor & material handling
Factory automation
Life science & medical
Machine tools
Packaging machinery
Transportation & automotive

Key Products

Air preparation
Brass fittings & valves
Manifolds
Pneumatic accessories
Pneumatic actuators & grippers
Pneumatic valves & controls
Quick disconnects
Rotary actuators
Rubber & thermoplastic hose & couplings
Structural extrusions
Thermoplastic tubing & fittings
Vacuum generators, cups & sensors



Process Control

Key Markets

Alternative fuels
Biopharmaceuticals
Chemical & refining
Food & beverage
Marine & shipbuilding
Medical & dental
Microelectronics
Nuclear Power
Offshore oil exploration
Oil & gas
Pharmaceuticals
Power generation
Pulp & paper
Steel
Water/wastewater

Key Products

Analytical Instruments
Analytical sample conditioning products & systems
Chemical injection fittings & valves
Fluoropolymer chemical delivery fittings, valves & pumps
High purity gas delivery fittings, valves, regulators & digital flow controllers
Industrial mass flow meters/controllers
Permanent no-weld tube fittings
Precision industrial regulators & flow controllers
Process control double block & bleeds
Process control fittings, valves, regulators & manifold valves



Sealing & Shielding

Key Markets

Aerospace
Chemical processing
Consumer
Fluid power
General Industrial
Information technology
Life sciences
Microelectronics
Military
Oil & gas
Power generation
Renewable energy
Telecommunications
Transportation

Key Products

Dynamic seals
Elastomeric o-rings
Electro-medical instrument design & assembly
EMI shielding
Extruded & precision-cut, fabricated elastomeric seals
High temperature metal seals
Homogeneous & inserted elastomeric shapes
Medical device fabrication & assembly
Metal & plastic retained composite seals
Shielded optical windows
Silicone tubing & extrusions
Thermal management
Vibration dampening



European Headquarters
La Tuilière 6, 1163 Etoy,
Switzerland
Tel: +41 21 821 85 00

Your authorized distributor